



# Retractable Barrier Tape Racking Kit

Designed for mobile safety management, the Retractable Barrier Tape Racking Kit enables teams to quickly cordon off racking aisles or work zones during maintenance or temporary closures. Housed in a sturdy, transportable case, this kit provides a fast, flexible solution to restrict access and maintain compliance wherever it's needed.





Strong magnetic parts allow for rapid, tool-free installation onto racking or other steel structures.



Designed to be carried by one person, the sturdy case houses everything needed for fast deployment.



Ideal for use in maintenance, cleaning, or temporary shutdowns in warehouse and logistics environments.



High tensile webbing clearly defines restricted areas to protect workers and prevent unauthorised access.



**Racking Kit**  
 Products supplied in a robust portable carry case  
 Contains -  
 2 x Retractable Tape Units  
 2 x Attachment Units  
 2 x Receiver Units  
 8 x Magnets for easy fixing

## Technical Information

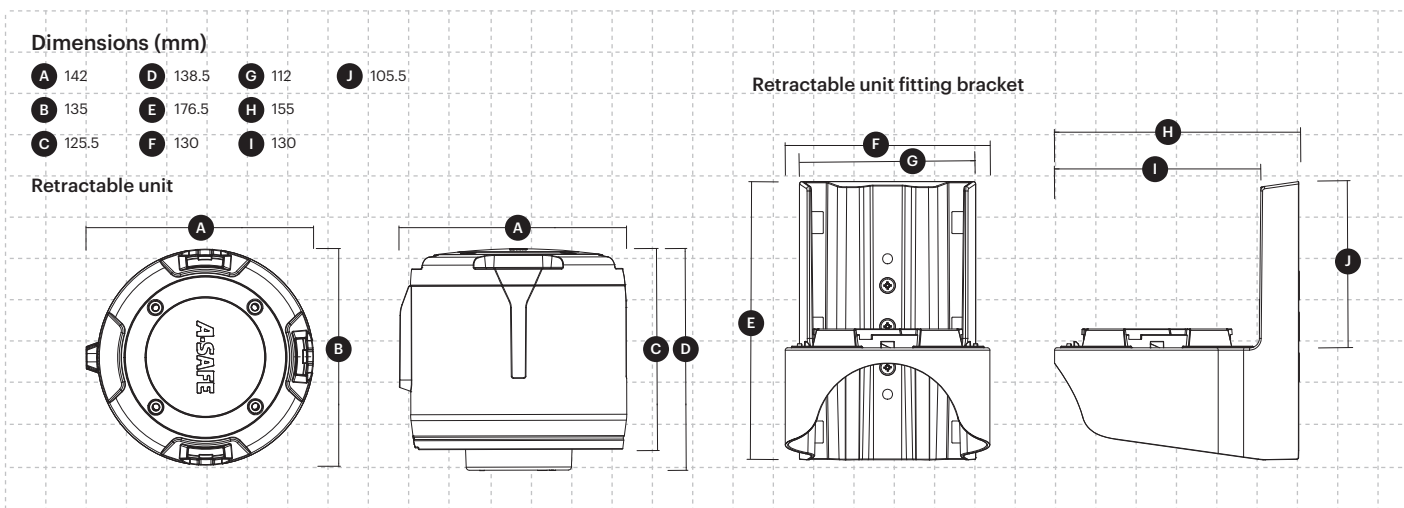

Please note: The Retractable Barrier webbing will sag when pulled out to the following widths. (Sag measurements are approximate).

Total webbing width	Amount of sag
3m	25mm
4.5m	70mm
5m	80mm
7m	130mm
9m	150mm

